



Figure 1: Typical Side Wall Termination

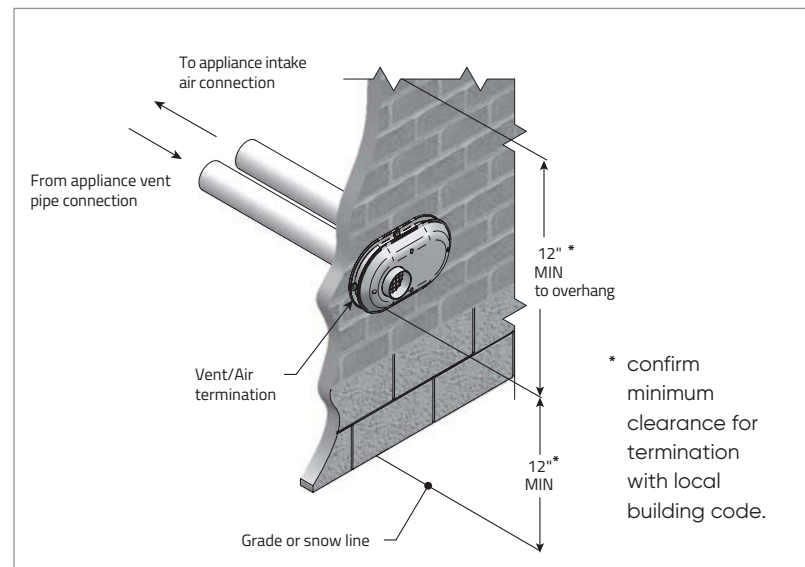

Figure 2: Approved Installation Orientation



Figure 3: Sidewall Termination Assembly

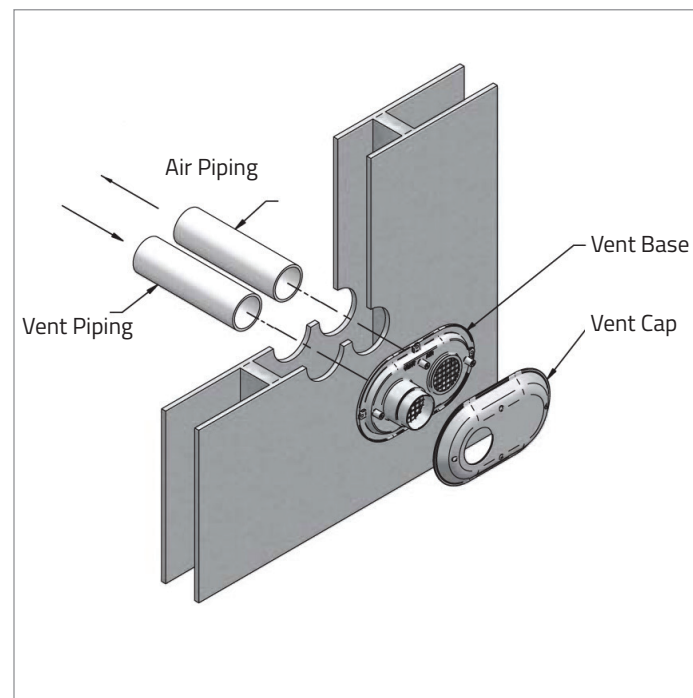
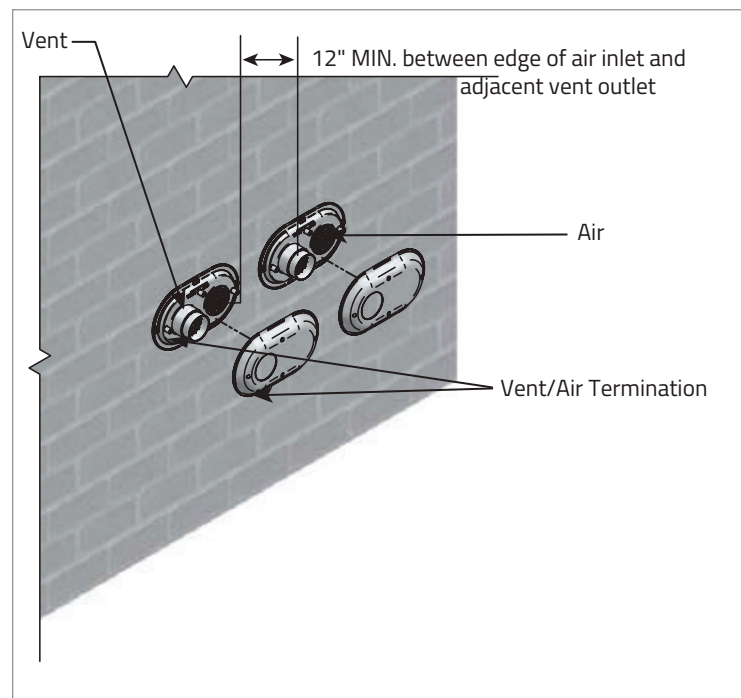
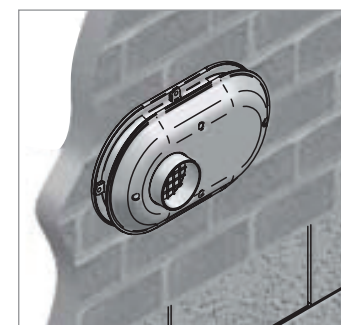

Figure 4: Minimum Clearances: Multiple Side Wall Terminations



SYSTEM 1738® (UL 1738 / ULC S636)

1. Refer to the appliance manufacturer's installation instructions to ensure that the low profile side wall termination kit is permitted for use. The IPEX Low Profile side wall termination kit is fully certified to UL 1738 and ULC S636.
2. In the USA, this termination is for use with only System 1738 products unless mixing of components from different vent manufacturers is allowed by the authority having jurisdiction.
3. In Canada, this kit is for use with only System 636 products.



System 1738 PVC Low Profile vent kits are made from an engineered PVC compound certified to both UL 1738 and ULC S636 standards and are rated to a maximum temperature of 149°F.

The vent termination must maintain all termination clearances and be

installed in accordance with local building code and NFPA 54 / ANSI Z223.1 National Fuel Gas Code in the United States and CSA B149.1 National Fuel Gas Code in Canada (see figure 1).

Table 1

Each Kit Contains	
Qty	Item Description
1	Base (two holes)
1	Cap (one hole)
8	Stainless Steel Screws
4	Plastic Anchors

Refer to Figure 3 for side wall termination assembly

Table 2

Low Profile Termination Kits Dimensions			
Item #	Flush Mount Vent Kit Size	Pipe O.D.	Hole Spacing (ctr to ctr)
397100	2"	2.375"	5.6"
397101	3"	3.5"	5.6"

Installation Procedure

1. When locating the penetration of the vent and air pipe, ensure the termination is properly oriented as shown in Figure 2 and ensure that it maintains minimum clearance requirements as shown in Figure 1. For multiple vent terminations, ensure that a minimum clearance of 12 inches is maintained between edge of air inlet and adjacent vent outlet and that all vent pipes and air inlets terminate at the same height to avoid the recirculation of flue gases and the possibility of causing severe personal injury, death, or substantial property damage. (see Figure 4)
2. When installing the vent termination in a vertical configuration, ensure the vent piping is located above the air inlet piping. This will avoid the risk of flue gas products recirculating into the air inlet and building. (see Figure 2).
3. Once the installer has determined the termination location, cut 2 holes in the wall large enough to accommodate the pipe. Pipe diameters and distance between hole centers can be found in Table 2 or by using the template on reverse.
4. Slide both the intake and vent pipe through the holes. Solvent weld both pipes to the Base of the vent termination kit (see Figure 3) following the solvent welding procedures outlined in the System1738 (United States) and System 636 (Canada) Installation Methods Guide found at system1738.com and system636.com.
5. To fasten the Base to the wall, use the supplied screws and anchors. A 3/16" diameter x 1-3/16" deep hole, will need to be drilled for the anchors. Locate and mark the anchor hole using the Base as a template and then drill the required holes.
6. Screw the Cap to the Base using the supplied screws.
7. Once the vent termination and pipe are secured, the wall penetrations will need to be sealed from the interior using a PVC-compatible sealant material.

TEMPLATE

FOR CUTTING HOLE ON AN EXTERIOR WALL FOR SYSTEM 1738 LOW PROFILE VENT FIT INSTALLATION
P/N 397000, 397001

